

REV	DATE	ECO	DESCRIPTION	BY	CK	APP
-	6-1-09	N/A	INITIAL RELEASE	LDB	N/A	N/A

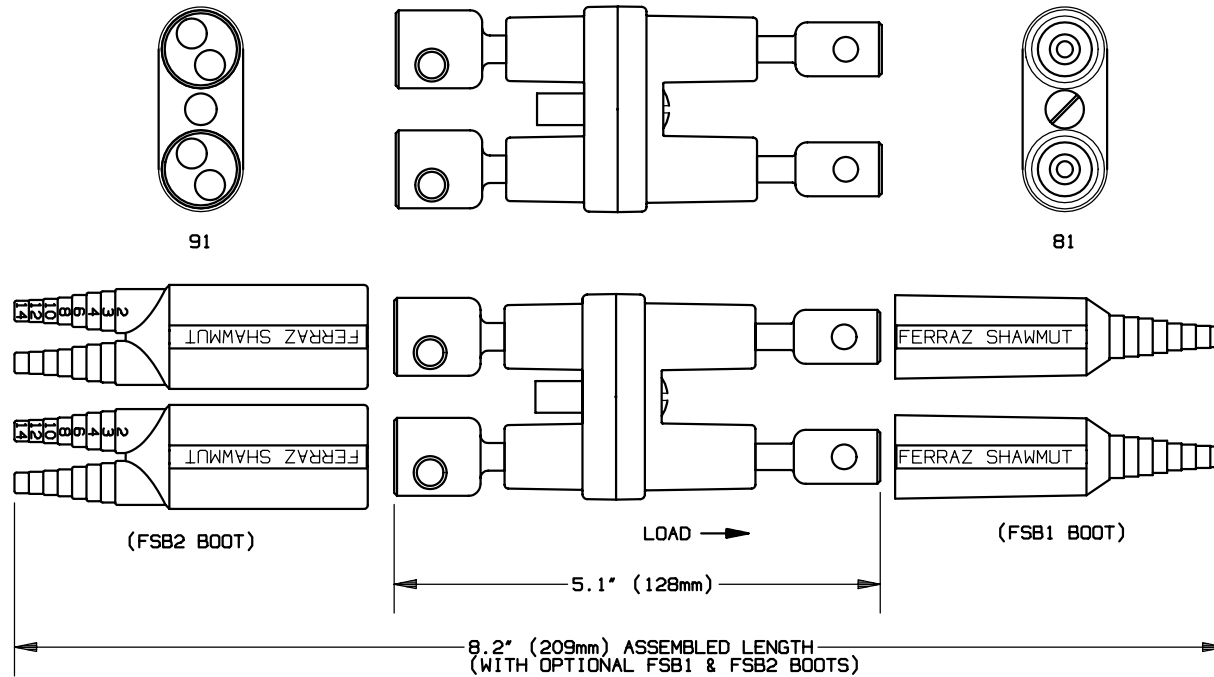

P/N	AMPERE RATING	RMS SYM RATING	CONN TYPE	TORQUE (LBS-IN)	WIRE			UL		CSA		
					WIRE RANGE	°C	TYPE	FILE NO.	GUIDE NO.	FILE NO.	CLASS	
FEY-81-91	30	200,000	81-Cu SINGLE SET SCREW	50	{1} #2-3 SOL/STR	75	Cu	E52283	IZLT	32169	6225	
				35								{1} #4-6 SOL/STR
				25								{1} #8 SOL/STR
				20								{1} #10-12 SOL/STR
			91-Cu DOUBLE SET SCREW	50	{1} #2-3 SOL/STR							
				35								{1} #4-6 SOL/STR
				25								{1} #8 SOL/STR
				20								{1} #10-12 SOL/STR

**Ferraz Shawmut**  
 FERRAZ SHAWMUT INC.  
 374 MERRIMAC STREET  
 NEWBURYPORT, MA 01950

PRODUCT MANAGER      DESIGN ENGINEER

SIGN:                                  SIGN:  
 DATE:                                  DATE:

FUSE HOLDER, 600V-30A,  
 2 POLE, IN-LINE,  
 CLASS CC

OUTLINE DIMENSIONS  
 NOT TO BE USED FOR PRODUCTION

701484