



Your problem: You're facing the enormously complex wiring requirements of an automated manufacturing facility. Or the compatibility problems of a commercial complex retrofit. Or the need for seamless electrical service in a hospital annex that's anything but seamless. Where can you turn to solve your power distribution problems?

Our solution: Well beyond circuit protection solutions. Mersen offers you an arsenal of circuit management products. One of which is our line of polycarbonate 600V / 90 to 1520A Power Distribution Blocks. Safe and convenient, durable and easy to install, they're the simple way to split primary power circuits into secondary circuits — or provide fixed-junction tap-off points. Mersen's comprehensive line of PDBs includes open style and enclosed blocks in a wide range of configurations. Copper and aluminum blocks are available in either style with a full complement of accessories.

Want more information fast?

For more technical or application-specific information, please call our Power Distribution Block experts at 978-248-8914 or visit our website at mersen.com.

Power Distribution Blocks

**A POWERFUL WAY TO
MANAGE YOUR POWER
DISTRIBUTION CHALLENGES**

- Compact PDB. PD 2
- FSPDB Series Finger-Safe Power Distribution Blocks PD 6
- MPDB Series Open-Style Power Distribution Blocks PD 8
- MPDB62-MPDB63 (Mini) Open-Style PDBs. PD 10
- MPDB66-MPDB67 (Intermediate) Open-Style PDBs. PD 11
- MPDB68-MPDB69 (Large) Open-Style PDBs. PD 13
- MPDB Double-Wide Open-Style PDBs. PD 15
- Dimensions PD 16



Compact PDB

Compact EP Power Distribution Blocks

POWER DISTRIBUTION BLOCKS

THE NEXT LEVEL OF SAFETY AND EASE OF INSTALLATION



RATINGS:

- **Volts:** 600VAC/DC
- **Amps:** 85 to 250A
- **SCCR:** 600V or less, 100kA with proper fuse; over 600V, 10kA

Contact Technical Services for instruction sheet.

APPROVALS:

- UL recognized:
UL file # E73571
- CSA certified: Class 6228



Mersen's finger safe IP20-rated Power Distribution Blocks are part of the new Compact EP® line of products. The compact footprint allows space savings in panels, contributing to reduced panel size when compared to traditional power distribution blocks.

The Compact PDB is ideal for low voltage applications. Rated for UL-600V, ampere range of 85-250A, it can accommodate wire ranges AWG 18-3/0, catering to a wide range of low voltage applications. The PDBs can be DIN rail mounted, are dual wire rated, and are capable of DLO wire acceptance allowing ease of installation. Translucent covers allow visual inspection of wire termination points and wiring configurations.

FEATURES/BENEFITS:

- **Finger-safe protection:** Fully insulated block ensures touch-safe isolation of live parts. Recessed termination screws and wire openings provide IP20 grade protection and qualify as "fingersafe" per IEC 529. Translucent cover allows for visual inspection of wire termination.
- **Compact modularity:** Smaller footprint allows panel builders to reduce space and build smaller or higher density panels.
- **Snap on DIN-rail mounting:** Integral DIN rail adaptors allow for quick and easy installations on 35mm DIN rail, yielding lower installed costs.
- **Captive termination screws:** Unique channel design ensures captive metric wire termination screws. Screws can never be lost.
- **Multiple wire ratings:** Blocks are multi wire rated - see multi wire rating table and can accommodate 18AWG wire for low voltage applications such as LED lighting. Can also accept DLO wires.

CATALOG NUMBERS

Catalog Number	Ampere Rating	Wire Hole Range	Hex Driver Size	Line Side			Load Side						Max Current	
				Wire Strip Back Length	Wire Size	Torque	Load Side Location	Wire Hole Range	Hex Driver Size	Wire Strip Back Length	Wire Size	Torque	Cu	Al
CEP-FSPDB85	85	#4-#14	1/8"	.575"	#4	50 in-lbs	Top	(3)#8-#16	1/16"	.575"	#5-#10	8 in-lbs	85	65
					#6-#14	33 in-lbs					#12-#16	5 in-lbs		
					-	-	Bottom	(2)#6-#14	1/8"		#6	50 in-lbs		
CEP-FSPDB115	115	{2}#2-#14	5/32"	.575"	#2	140 in-lbs	Top	(4)#8-#16	1/16"	.425"	#8-#10	8 in-lbs	115	90
					#4	125 in-lbs					#12-#16	5 in-lbs		
					#6-#14	50 in-lbs	Bottom	(3)#4-#14	1/8"		#4-#14	50 in-lbs		
CEP-FSPDB160	160	{2}#2/0-#10	7/32"	.775"	#2/0-2	165 in-lbs	Top	(3)#6-#14	1/8"	.500"	#6	50 in-lbs	160	135
					#4-#14	50 in-lbs					#8-#14	35 in-lbs		
					-	-	Bottom	(3)#4-#14	1/8"		#4-#14	50 in-lbs		
CEP-FSPDB200	200	#4/0-#10	1/4"	.875"	#4/0	250 in-lbs	All	(8)#4-#14	1/8"	.625"	#4-#14	50 in-lbs	200	155
					#3/0-#1/0	220 in-lbs					-	-		
					#1-#10	150 in-lbs	-	-	-		-			
CEP-FSPDB250	250	{2}#250-#6	1/4"	1.00"	#250-#4/0	250 in-lbs	Top	(4)#6-#14	1/8"	.525"	#6	50 in-lbs	250	205
					#3/0-#2/0	200 in-lbs					#8-#14	35 in-lbs		
					#1/0-#6	150 in-lbs	Middle	(3)#4-#14	1/8"		#4-#14	50 in-lbs		
					-	-	Bottom	(3)#2-#14	5/32"		#2	140 in-lbs		
										#4-#14	50 in-lbs			

MULTI-WIRE RATINGS TABLE

Catalog Number	Load Side Location	Wire Size	Torque
CEP-FSPDB85	Top	(4)#16-#18;	5 in-lbs
	Bottom	(2)#16-#18	35 in-lbs
CEP-FSPDB115	Top	(4)#16-#18;	5 in-lbs
	Bottom	(2)#16-#18	50 in-lbs
CEP-FSPDB160	Top	(4)#16-#18;	35 in-lbs
	Bottom	(2)#16-#18	50 in-lbs
CEP-FSPDB200	All	(4)#16-#18;	50 in-lbs
		(2)#16-#18	
CEP-FSPDB250	Top	(4)#16-#18	35 in-lbs

Please note: These PDBs are made for copper, compact copper, DLO, and aluminum wires.

VOLTAGE RATING, MOUNTING TYPE, AND ENCLOSURE SIZE

Catalog Number	Voltage	Minimum Enclosure Size
CEP-FSPDB85	600V or less	12" x 6" x 8"
CEP-FSPDB115	600V or less	12" x 6" x 8"
CEP-FSPDB160	600V or less	12" x 20" x 8"
CEP-FSPDB200	600V or less	12" x 20" x 8"
CEP-FSPDB250	600V or less	24" x 20" x 10"

Enclosure size was based on UL testing. Suitability of smaller enclosure can be determined in end-use investigation.

IP20 WITH WIRE INSTALLED

Catalog Number	Line Side				Load Side				
	Installed Wire	Trim Length in. (mm)	Conductor Opening	IP20 Screw Opening	Load Side Location	Installed Wire	Trim Length in. (mm)	Conductor Opening	IP20 Screw Opening
CEP-FSPDB85	4 to 14 AWG	.575"	Yes	Yes	Top	8 to 16 AWG	.575"	Yes	Yes
					Bottom	6 to 14 AWG			
CEP-FSPDB115	2 to 14 AWG	.575"	Yes	Yes	Top	8 to 16 AWG	.425"	Yes	Yes
					Bottom	4 to 14 AWG			
CEP-FSPDB160	2/0 to 14 AWG	.775"	Yes	Yes	Top	6 to 14 AWG	.500"	Yes	Yes
					Bottom	4 to 14 AWG			
CEP-FSPDB200	4/0 to 10 AWG	.875"	No	Yes	All	4 to 14 AWG	.625"	Yes	Yes
CEP-FSPDB250	250 to 6 AWG	1.00"	No	Yes	Top	6 to 14 AWG	.525"	Yes	Yes
					Middle	4 to 14 AWG			
					Bottom	2 to 14 AWG			

MOUNTING INSTRUCTIONS

DIN Rail Mounting

2. Push forward to compress
DIN rail mounting spring →

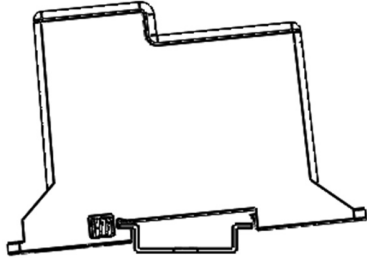

1. Hook line side over 35mm DIN Rail

3. Push down
until "Click"

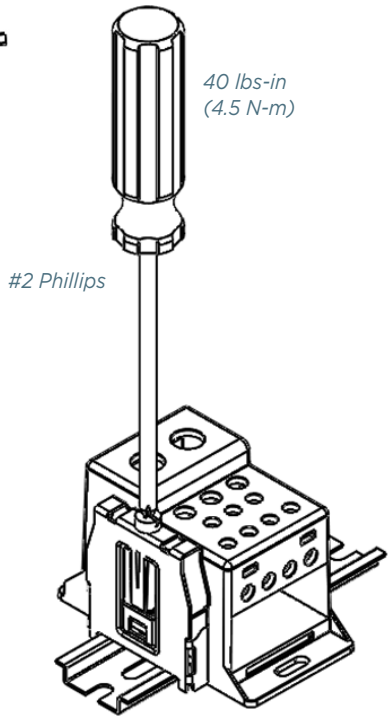

#2 Phillips

40 lbs-in
(4.5 N-m)

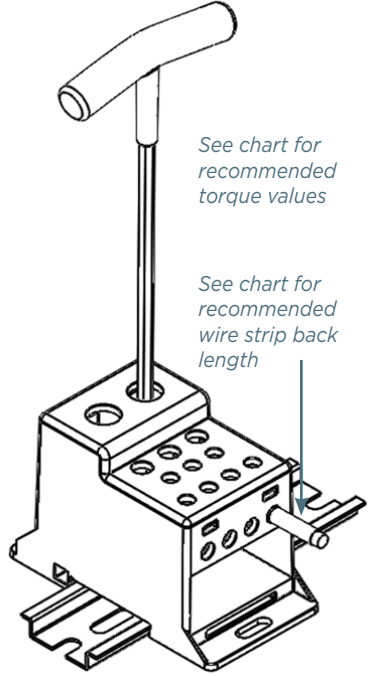

See chart for
recommended
torque values

See chart for
recommended
wire strip back
length

FSEA Anchor (one each side of block) MUST be used for mounting single pole CEP-FSPDBs to prevent damage to the block while tightening terminals.

FSEA Anchor recommended for all CEP-FSPDB on DIN Rails

Panel Mounting

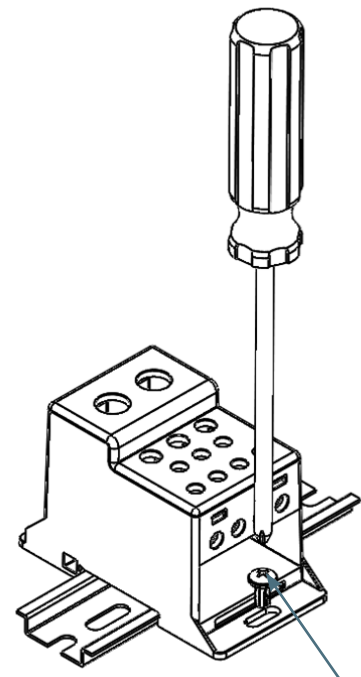

Use 2 screws
For mounting single pole

#10 or M5

Environmental Specifications

- Operating temperature range -10°C to 40°C
- Storage temperature range -25°C to 90°C

© 2024 Mersen. All rights reserved. Mersen reserves the right to change, update, or correct, without notice, any information contained in this datasheet.

DIMENSIONS

CEP-FSPDB85

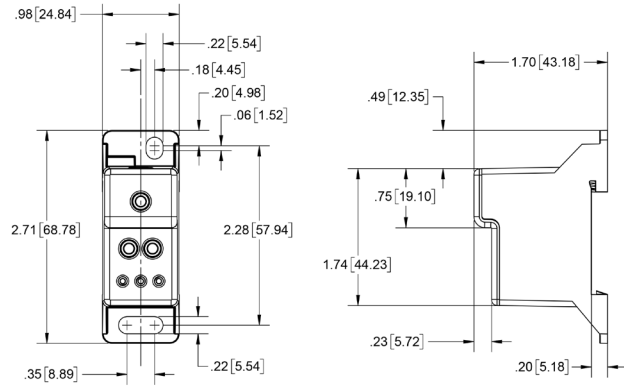

CEP-FSPDB115

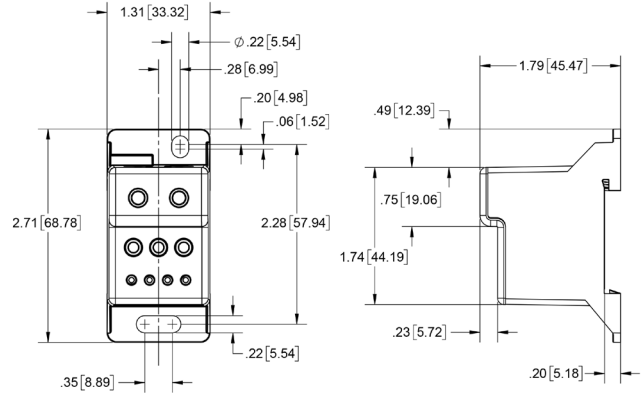

CEP-FSPDB160

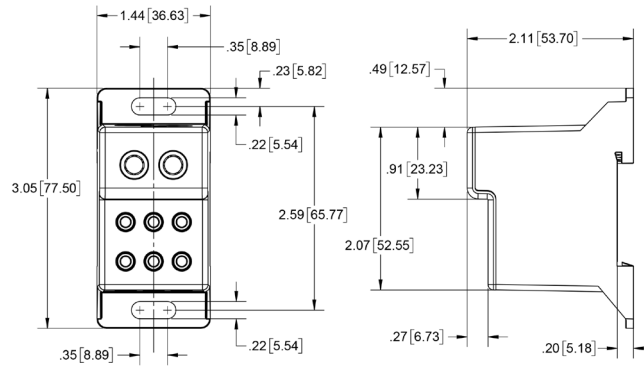

CEP-FSPDB200

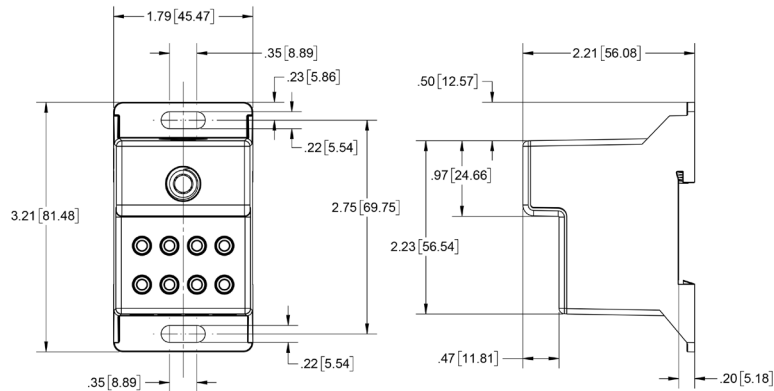

CEP-FSPDB250

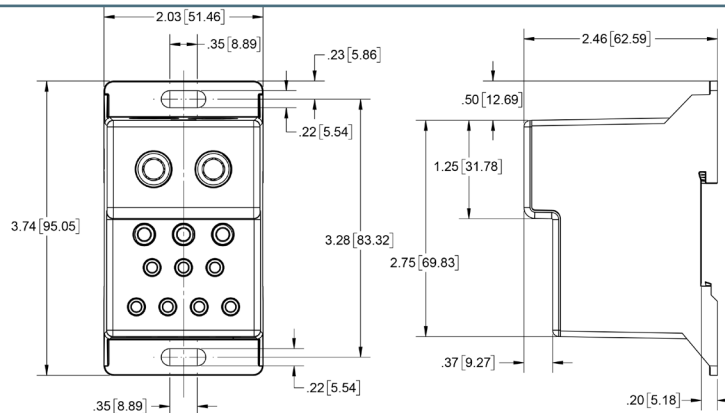

FSPDB

Finger-Safe Power Distribution Blocks

POWER DISTRIBUTION BLOCKS

SAFETY EVOLVING



Mersen FSPDBs introduce a new level of safety and ease for installing power distribution blocks. An IP20 level of finger-safe protection is achieved using FSPDBs, eliminating the need for special covers or custom plexiglass sheets to protect your panels. FSPDBs (sizes 1 to 4) simply snap onto 35mm DIN rail to provide the quickest installation. Modular design also allows for multi pole applications by use of assembly pins. FSPDBs provide a safe, convenient way of splicing cables, splitting primary power into a variety of secondary circuits or providing a fixed junction tap-off point.

FEATURES/BENEFITS:

- **Finger-safe protection:** Fully insulated block ensures touch safe isolation of live parts. Recessed termination screws and wire openings provide IP20 grade protection and qualify as “finger-safe” per IEC 529.
- **Compact modularity:** Single or multiple pole configurations in the most compact footprint. Allows users to build smaller or higher density panels.
- **Snap on DIN-rail mounting:** Sizes 1 to 4 feature integral DIN rail adaptors allowing for quick and easy installations on 35mm DIN rail yielding lower installed costs.
- **Captive termination screws:** Unique channel design ensures captive metric wire termination screws. Screws can never be lost.
- **Available accessories:** For multi-pole panel mounting, simply snap in pins for rigid fit. Cap plugs provide the ability to maintain touch safety on unused openings. Circuit identification markers simply snap into blocks to ID circuits. End anchors provide rigid end stops. (Continued on next page.)

RATINGS:

- **Volts:** FSPDB1,2,3—1500VAC/DC; FSPDB4,5—600VAC/DC
- **Amps:** 175 to 840A
- **SCCR:** 600V or less, 100kA with proper fuse; Over 600V, 10kA

Contact Technical Services for instruction sheet.

APPROVALS:

- UL Recognized Component
 - FSPDB 1, 2, 3: File E73571
 - FSPDB 4, 5: File E493667
- CSA Certified: Class 6228, File 69363
- IEC-947-7-1, 529, 68-2-6, CE Marked



FEATURES/BENEFITS (CONTINUED):

- **Multiple wire ratings:** Provide users more versatility by offering capability of using multiple conductors in #2 and 2/0 openings.
- **AC & DC ratings:** FSPDB1, 2, and 3 have been evaluated for use at 1500V (AC or DC) provided they are installed on DIN-rails only and with proper barriers and spacing between poles of opposite polarity.

CATALOG NUMBERS

Catalog Number		Ampere Rating (Based on NEC Table 310-16 for 75° C Cu wire only)	Line			Load			Short Circuit Current Rating
Aluminum (Connector rated for 90° C Cu/AL wire)	Copper (Connector rated for 75° C Cu wire only)		Wire Range		Openings	Wire Range		Openings Per Pole	
			AWG/	mm ²		AWG/ kcmil	mm ²		
FSPDB1A	FSPDB1C	175	2/0-#14	70-2.5	1	2/0-#14	70-2.5	1	100kA*
FSPDB2A	FSPDB2C	175	2/0-#14	70-2.5	1	#2-#14	35-2.5	4	100kA*
FSPDB3A	FSPDB3C	310	350-#6	185-16	1	#2-#14	35-2.5	8	100kA*
			2/0-#14	70-2.5					
FSPDB4A	FSPDB4C	335	400-#6	185-16	1	400-#6	185-16	1	100kA*
FSPDB5A**	FSPDB5C	840	600-#4	300-25	2	600-#4	300-25	2	100kA*

*Contact Mersen Technical Services at technicalservices.nby@mersen.com for fuse type and maximum ampere required.

** FSPDB5A is not DIN-rail mountable.

Multiple Wire Ratings (Same Size & Type Wires Only)					
2/0 Openings			#2 Openings		
{2} #4 AWG	{2} #8 AWG	{2} #12 AWG	{2} #6 AWG	{2-4} #10 AWG	{2-4} #14 AWG
{2} #6 AWG	{2} #10 AWG	{2} #14 AWG	{2} #8 AWG	{2-4} #12 AWG	

DIMENSIONS

Dimension	FSPDB1A FSPDB1C Figure 1		FSPDB2A FSPDB2C Figure 1		FSPDB3A FSPDB3C Figure 2		FSPDB4A FSPDB4C Figure 1		FSPDB5A FSPDB5C Figure 2	
	mm	in	mm	in	mm	in	mm	in	mm	in
A	25.4	1.00	28.4	1.12	46.9	1.85	39	1.54	72	2.84
B	43.3	1.70	57.8	2.28	64.3	2.53	108	4.25	91	3.58
C	49.5	1.95	56.0	2.21	64.3	2.53	80	3.15	80	3.15
D	45.1	1.78	51.6	2.03	59.8	2.36	75.5	2.97	-	-
E	39.4	1.55	39.4	1.55	51.5	2.03	50.1	1.97	50.1	1.97
F	72.6	2.86	87.7	3.45	100.8	3.97	145.5	5.73	145	5.71
G	59.6	2.35	74.6	2.94	82.4	3.24	120.6	4.75	127.5	5.02
H	5.3	0.21	5.1	0.20	6.5	0.26	7	0.28	3	0.12
I	-	-	-	-	31.5	1.24	-	-	52	2.04
J	5.3	0.21	6.4	0.25	6.5	0.26	6.5	0.26	6.5	0.26
K	10	0.40	11.7	0.46	8.9	0.35	16	0.63	8.5	0.34

ACCESSORIES

Catalog No.	Description
FSPIN1	Accessory pin to form multiple pole block
FSCIM1	Circuit identification marker for 2/0 & #2 max. conductors (80 per card)
FSCIM2	Circuit identification marker for 350, 400 & 600 kcmil max. conductors (56 per card)
FSCAP1	Cap plug for spare 2/0 openings
FSCAP2	Cap plug for spare 350 kcmil openings
FSCAP3	Cap plug for spare 600 kcmil opening
FSEA	Pair of end anchors

Figure 1

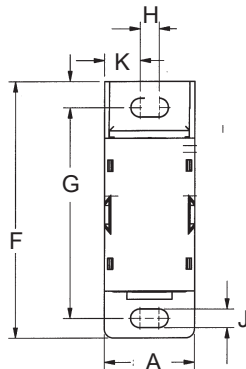
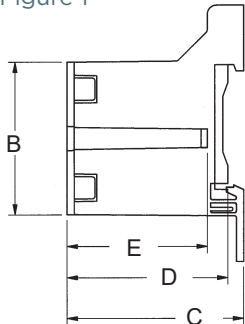
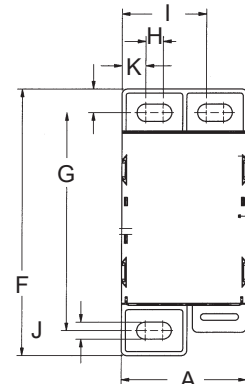
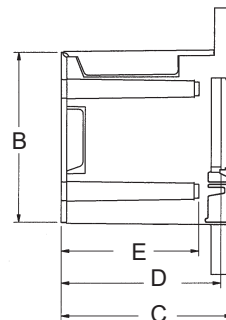

Figure 2



MPDB Series

Open-Style Power Distribution Blocks

POWER DISTRIBUTION BLOCKS

THE NEXT GENERATION POWER DISTRIBUTION BLOCK (PDB)

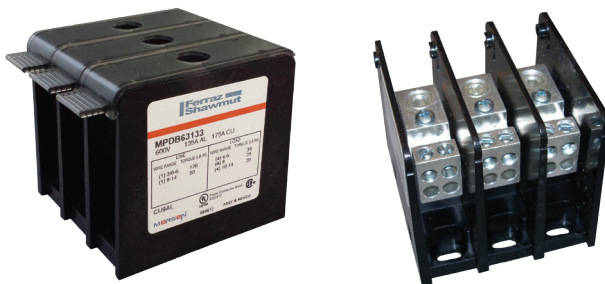

Mersen power distribution blocks provide a safe and easy method of splicing cables, splitting primary power into secondary circuits and fulfilling requirements for fixed junction tap-off points. Unless noted otherwise, all blocks are UL and CSA approved while meeting spacing requirements for feeder and branch circuits in conjunction with UL508A and the National Electrical Code®. PDB options include single or dual conductor primary inputs and up to 30 secondary outputs. Specialty blocks are available allowing for up to 7 primary inputs. The MPDB series is offered in three size categories: miniature (MPDB62 and MPDB63 series), intermediate (MPDB66 and MPDB67 series), and large (MPDB68 and MPDB69 series), in both aluminum and copper.

FEATURES/BENEFITS:

- **Adder Poles:** All sizes have optional adder poles for increased flexibility and ease-of-use. Adder poles can be stacked to form multi-pole units in the field without the use of tools. Adder poles allow for customization of primary and secondary wire combinations. End barriers are also available for sale, catalog numbers can be found in the catalog number selection tables for each size block.
- **Wire Connectors:** Standard aluminum and copper wire connectors are available. Aluminum connectors accept both AL or CU wire while copper connectors accept CU wire only. Connectors are all 1-piece tin-plated. Many part numbers are rated to accept DLO-type fine-strand wire, allowing users to connect flexible conductors. (Continued on next page.)

RATINGS:

- **Volts:** 1000VAC/DC
- **Amps:** 65 to 2260A based on NEC table 310.15(B)(16) 75°C ampacities
- **SCCR:** 100kA with properly sized fuse (See Mersen's PDB SCCR guide at ep.mersen.com or contact Mersen Technical Services)

APPROVALS:

- UL Listed to subject 1953, File E352417 unless noted otherwise
- CSA Certified Class 6228 01



FEATURES/BENEFITS (CONTINUED):

- **Insulators:** Insulators are virtually unbreakable, made of glass-filled polycarbonate. “See-through,” hinged safety covers are optional and provide a greater degree of safety and shock resistance where required. Hinged covers can be installed without tools.
- **Spacings:** 1 inch through air and 2 inches over surface between uninsulated live parts of opposite polarity meets requirements for feeder and branch circuit applications of UL508A.
- **Safety Covers:** Polycarbonate safety covers provide dead-front protection. One cover is needed for each pole. Each cover has a test probe hole in the center for circuit checking. Covers are optional accessories and catalog numbers can be found in the catalog selection tables for each size block.

ADDITIONAL SPECIFICATIONS:

- Wire Type:** Copper Blocks: 60/75°C Solid/Stranded CU; Aluminum Blocks: 60/75/90°C Solid/Stranded AL and CU
- Connector:** Copper Blocks: Highly conductive tin-plated copper; Aluminum Blocks: Highly conductive tin-plated aluminum
- Insulating Material:** Glass-filled polycarbonate with verified dielectric strength in excess of 2500V
- Flammability:** UL94-V0
- Mounting:** Direct panel mount
- Environmental:** RoHS compliant, Lead Free

PART SELECTION NOTES

MPDBs in each size category come in one, two, and three pole configurations (ending in -1, -2, and -3 accordingly). Users also have the ability to field install additional poles, end barriers, and safety covers.

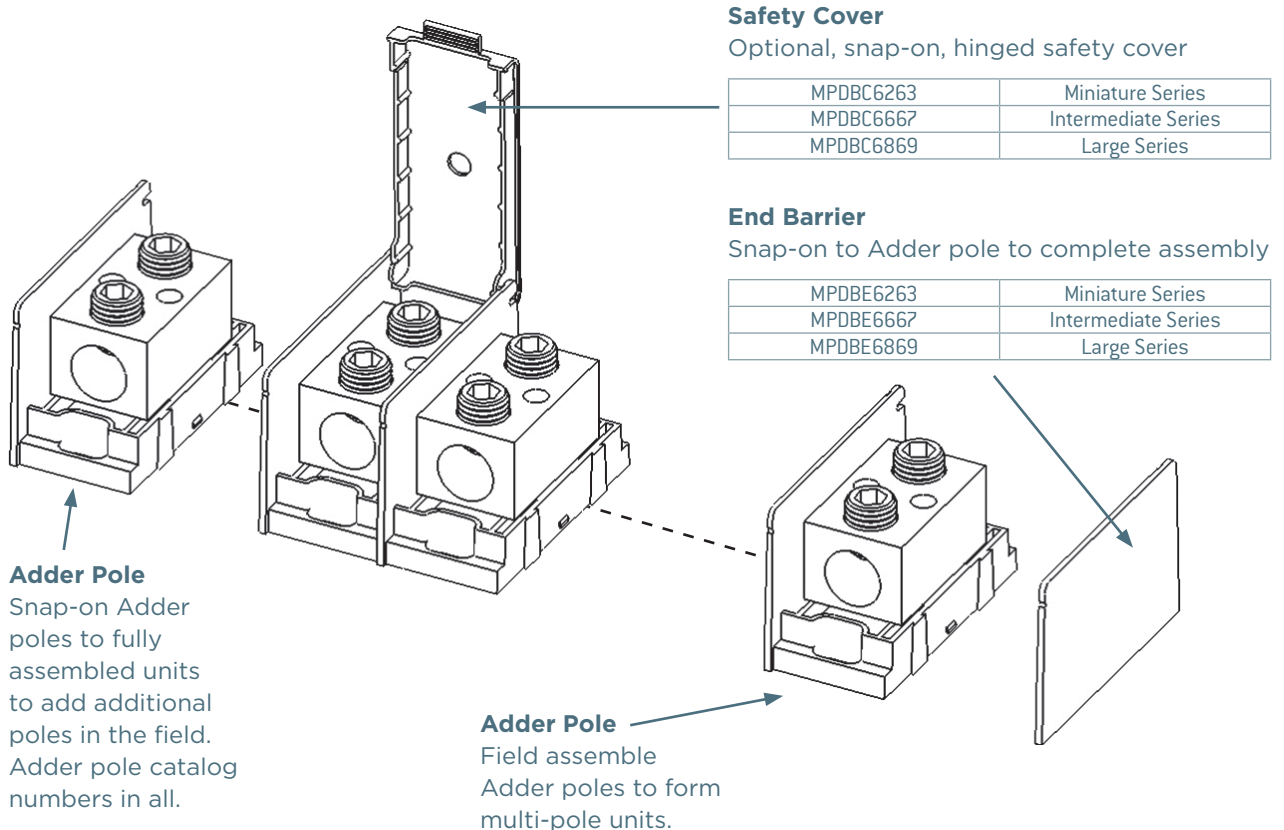

© 2024 Mersen. All rights reserved. Mersen reserves the right to change, update, or correct, without notice, any information contained in this datasheet.

**CATALOG NUMBERS, MINIATURE ALUMINUM MPDBs,
BOX-BOX CONFIGURATION**

Line Side		Load Side		Catalog Numbers				Ampere Rating per Pole	
Wire Range	Openings per Pole	Wire Range	Openings per Pole	ADDER	1-P	2-P	3-P	Cu Wire	Al Wire
4-14	1	4-14	1	MPDB63100	MPDB63101	MPDB63102	MPDB63103	85	65
4-14	1	4-14	4	MPDB63160	MPDB63161	MPDB63162	MPDB63163	85	65
6-14 (DLO)		6-14 (DLO)						65 (DLO)	
2/0-14	1	2/0-14	1	MPDB63150	MPDB63151	MPDB63152	MPDB63153	175	135
1/0-14 (DLO)		1/0-14 (DLO)						125 (DLO)	
2/0-14	1	2-14	2	MPDB63190	MPDB63191	MPDB63192	MPDB63193	175	135
1/0-14 (DLO)		3-14 (DLO)						125 (DLO)	
2/0-14	1	4-14	4	MPDB63130	MPDB63131	MPDB63132	MPDB63133	175	135
1/0-14 (DLO)		6-14 (DLO)						125 (DLO)	

(DLO) Indicates Ampere Rating or Wire Range applicable to DLO class wire.

**CATALOG NUMBERS, MINIATURE ALUMINUM MPDBs,
BOX-STUD CONFIGURATION**

Line Side		Load Side		Catalog Numbers				Ampere Rating per Pole	
Wire Range	Openings per Pole	Stud Size	Studs per Pole	ADDER	1-P	2-P	3-P	Ratings (Cu)	Ratings (Al)
2/0-14	1	1/4" - 20 x 5/8"	1	MPDB63140	MPDB63141	MPDB63142	MPDB63143	175	135

**CATALOG NUMBERS, MINIATURE COPPER MPDBs,
BOX-BOX CONFIGURATION**

Line Side		Load Side		Catalog Numbers				Ampere Rating per Pole
Wire Range	Openings per Pole	Wire Range	Openings per Pole	ADDER	1-P	2-P	3-P	Rating (Cu)
4-14	1	4-14	1	MPDB62100	MPDB62101	MPDB62102	MPDB62103	85
4-14	1	4-14	4	MPDB62160	MPDB62161	MPDB62162	MPDB62163	85
2/0-14	1	2/0-14	1	MPDB62150	MPDB62151	MPDB62152	MPDB62153	175
2/0-14	1	2-14	2	MPDB62190	MPDB62191	MPDB62192	MPDB62193	175
2/0-14	1	4-14	4	MPDB62130	MPDB62131	MPDB62132	MPDB62133	175

(DLO) Indicates Ampere Rating or Wire Range applicable to DLO class wire.

**CATALOG NUMBERS, MINIATURE COPPER MPDBs,
STUD-STUD CONFIGURATION**

Line Side		Load Side		Catalog Numbers				Ampere Rating per Pole	
Stud Size	Studs per Pole	Stud Size	Studs per Pole	ADDER	1-P	2-P	3-P	Ratings (Cu)	Ratings (Al)
1/4"-20 X 5/8"	1	1/4"-20 X 5/8"	1	MPDB62200	MPDB62201	MPDB62202	MPDB62203	240	240

Hinged Safety Cover for MPDB62 and MPDB63 series: Catalog number MPDBC6263
End Barrier for MPDB62 and MPDB63 series: Catalog Number MPDBE6263

© 2024 Mersen. All rights reserved. Mersen reserves the right to change, update, or correct, without notice, any information contained in this datasheet.

**CATALOG NUMBERS, INTERMEDIATE ALUMINUM MPDBs,
BOX-BOX CONFIGURATION**

Line Side		Load Side		Catalog Numbers				Amp Rating per Pole	
Wire Range	Openings per Pole	Wire Range	Openings per Pole	ADDER	1-P	2-P	3-P	Cu Wire	Al Wire
2/0-14	1	2/0-14	1	MPDB67050	MPDB67051	MPDB67052	MPDB67053	175	135
2/0-14	1	2-14	4	MPDB67570	MPDB67571	MPDB67572	MPDB67573	175	135
1/0-14 (DLO)		4-14 (DLO)						150 (DLO)	
2/0-14	1	2-14	6	MPDB67560	MPDB67561	MPDB67562	MPDB67563	175	135
1/0-14 (DLO)		4-14 (DLO)						150 (DLO)	
2/0-14	1	2-14	8 ^M	MPDB67580	MPDB67581	MPDB67582	MPDB67583	175	135
1/0-14 (DLO)		4-14 (DLO)						150 (DLO)	
2/0-14	1	6-14	10 ^M	MPDB67590	MPDB67591	MPDB67592	MPDB67593	175	135
1/0-14 (DLO)		8-14 (DLO)						150 (DLO)	
2/0-14	1	10-14	12	MPDB67110	MPDB67111	MPDB67112	MPDB67113	175	135
1/0-14 (DLO)		12-14 (DLO)						150 (DLO)	
350-6	1	350-6	1	MPDB67000	MPDB67001	MPDB67002	MPDB67003	310	250
313-6 (DLO)		313-6 (DLO)						285 (DLO)	
350-6	1	2/0-14	2 ^M	MPDB67010	MPDB67011	MPDB67012	MPDB67013	310	250
313-6 (DLO)		1/0-14 (DLO)						2	
350-6	1	2-14	4 ^M	MPDB67670	MPDB67671	MPDB67672	MPDB67673	310	250
313-6 (DLO)		4-14 (DLO)						285 (DLO)	
350-6	1	2-14	6	MPDB67660	MPDB67661	MPDB67662	MPDB67663	310	250
313-6 (DLO)		4-14 (DLO)						285 (DLO)	
350-6	1	2-14	8	MPDB67630	MPDB67631	MPDB67632	MPDB67633	310	250
313-6 (DLO)		4-14 (DLO)						285 (DLO)	
350-6	1	6-14	10	MPDB67650	MPDB67651	MPDB67652	MPDB67653	310	250
350-6	1	10-14	15	MPDB67620	MPDB67621	MPDB67622	MPDB67623	310	250
500-4	1	500-4	1	MPDB67400	MPDB67401	MPDB67402	MPDB67403	380	310
500-4	1	350-6 & 2-14	1 & 3	MPDB67450	MPDB67451	MPDB67452	MPDB67453	380	310
500-4	1	4/0-10	2	MPDB67420	MPDB67421	MPDB67422	MPDB67423	380	310
500-4	1	2/0-14	4 ^M	MPDB67410	MPDB67411	MPDB67412	MPDB67413	350	310
373-4 (DLO)		1/0-14 (DLO)	4					320 (DLO)	
500-4	1	2-14	6 ^M	MPDB67460	MPDB67461	MPDB67462	MPDB67463	350	310
373-4 (DLO)		4-14 (DLO)	6					320 (DLO)	
500-4	1	2-14	8	MPDB67430	MPDB67431	MPDB67432	MPDB67433	380	310
500-4	1	6-14	10	MPDB67480	MPDB67481	MPDB67482	MPDB67483	380	310
500-4	1	10-14	18	MPDB67490	MPDB67491	MPDB67492	MPDB67493	380	310
2/0-14	2	2/0-14	2 ^M	MPDB67020	MPDB67021	MPDB67022	MPDB67023	350	270
1/0-14 (DLO)		1/0-14 (DLO)	2					300 (DLO)	
2/0-14	2	2-14	6	MPDB67510	MPDB67511	MPDB67512	MPDB67513	350	270
1/0-14 (DLO)		3-14 (DLO)						300 (DLO)	
2/0-14	2	2-14	8	MPDB67610	MPDB67611	MPDB67612	MPDB67613	350	270
2/0-14	2	6-14	10	MPDB67530	MPDB67531	MPDB67532	MPDB67533	350	270
2/0-14	2	10-14	15	MPDB67550	MPDB67551	MPDB67552	MPDB67553	350	270
4/0-6	2	4/0-6	2 ^M	MPDB67520	MPDB67521	MPDB67522	MPDB67523	460	360
3/0-6 (DLO)		3/0-6 (DLO)	2					400 (DLO)	
4/0-6	2	2-14	6 ^M	MPDB67540	MPDB67541	MPDB67542	MPDB67543	460	360
3/0-6 (DLO)		4-14 (DLO)	6					400 (DLO)	

* Indicates part numbers that are not UL listed (DLO) Indicates Ampere Rating or Wire Range applicable to Copper DLO class wire (M) Indicates connection UL approved for use with multiple conductors in the same opening. Quantities and sizes of wires are as follows:

2/0-#14 Openings	(4) #14	(4) #12	(2) #10						
4/0-#6 Openings	(2) #2	(2) #3	(2) #4	(2) #6					
500-#4 Openings	(2) #4	(2) #3	(2) #2	(2) #1	(2) 1/0	(2) #2/0	(2) 3/0		

**CATALOG NUMBERS, INTERMEDIATE ALUMINUM MPDBs,
BOX-STUD CONFIGURATION**

Line Side		Load Side		Catalog Numbers				Amp Rating per Pole	
Wire Range	Inputs	Stud Size	Outputs	ADDER	1-P	2-P	3-P	Ratings [Cu]	Ratings [Al]
350-6	1	3/8"-16 X 1-1/16"	1	MPDB67250	MPDB67251	MPDB67252	MPDB67253	310	250
500-4	1	3/8"-16 X 1-1/16"	1	MPDB67220	MPDB67221	MPDB67222	MPDB67223	380	310

Hinged Safety Cover for MPDB66 and MPDB67 series: Catalog number MPDBC6667

End Barrier for MPDB66 and MPDB67 series: Catalog Number MPDBE6667

**CATALOG NUMBERS, INTERMEDIATE COPPER MPDBs,
BOX-BOX CONFIGURATION**

Line Side		Load Side		Catalog Numbers				Ampere Rating per Pole	
Wire Range	Openings per Pole	Wire Range	Openings per Pole	ADDER	1-P	2-P	3-P	Cu Wire	
2/0-14	1	2/0-14	1	MPDB66050	MPDB66051	MPDB66052	MPDB66053	175	
2/0-14	1	2-14	4	MPDB66570	MPDB66571	MPDB66572	MPDB66573	175	
2/0-14	1	2-14	6	MPDB66560	MPDB66561	MPDB66562	MPDB66563	175	
2/0-14	1	2-14	8	MPDB66580	MPDB66581	MPDB66582	MPDB66583	175	
2/0-14	1	6-14	10	MPDB66590	MPDB66591	MPDB66592	MPDB66593	175	
2/0-14	1	10-14	12	MPDB66110	MPDB66111	MPDB66112	MPDB66113	175	
350-6	1	350-6	1	MPDB66000	MPDB66001	MPDB66002	MPDB66003	310	
350-6	1	2/0-14	2	MPDB66010	MPDB66011	MPDB66012	MPDB66013	310	
350-6	1	2-14	4	MPDB66670	MPDB66671	MPDB66672	MPDB66673	310	
350-6	1	2-14	6	MPDB66660	MPDB66661	MPDB66662	MPDB66663	310	
350-6	1	2-14	8	MPDB66630	MPDB66631	MPDB66632	MPDB66633	310	
350-6	1	6-14	10	MPDB66650	MPDB66651	MPDB66652	MPDB66653	310	
350-6	1	10-14	15	MPDB66620	MPDB66621	MPDB66622	MPDB66623	310	
500-4	1	500-4	1	MPDB66400	MPDB66401	MPDB66402	MPDB66403	380	
500-4	1	350-6 & 2-14	1 & 3	MPDB66450	MPDB66451	MPDB66452	MPDB66453	380	
500-4	1	2/0-14	4	MPDB66410	MPDB66411	MPDB66412	MPDB66413	380	
500-4	1	2-14	6	MPDB66460	MPDB66461	MPDB66462	MPDB66463	380	
500-4	1	10-14	18	MPDB66490	MPDB66491	MPDB66492	MPDB66493	380	
2/0-14	2	2/0-14	2	MPDB66020	MPDB66021	MPDB66022	MPDB66023	350	
2/0-14	2	2-14	6	MPDB66510	MPDB66511	MPDB66512	MPDB66513	350	
2/0-14	2	2-14	8	MPDB66610	MPDB66611	MPDB66612	MPDB66613	350	
2/0-14	2	6-14	10	MPDB66530	MPDB66531	MPDB66532	MPDB66533	350	
2/0-14	2	10-14	15	MPDB66550	MPDB66551	MPDB66552	MPDB66553	350	
4/0-6	2	4/0-10	2	MPDB66520	MPDB66521	MPDB66522	MPDB66523	460	
4/0-6	2	2-14	6	MPDB66540	MPDB66541	MPDB66542	MPDB66543	460	

(DLO) Indicates Ampere Rating or Wire Range applicable to DLO class wire

**CATALOG NUMBERS, INTERMEDIATE COPPER MPDBs, STUD-STUD
CONFIGURATION**

Line Side		Load Side		Catalog Numbers				Ampere Rating per Pole	
Stud Range	Studs per Pole	Stud Size	Studs per Pole	ADDER	1-P	2-P	3-P	Ratings (Cu)	Ratings (Al)
1/4"-20 X 1-5/16"	1	1/4"-20 X 1-5/16"	1	MPDB66270	MPDB66271	MPDB66272	MPDB66273	155	155
1/4"-20 X 1-5/16"	1	3/8"-16 X 1-1/8"	1	MPDB66200	MPDB66201	MPDB66202	MPDB66203	155	155
3/8"-16 X 1-1/8"	1	1/4"-20 X 1-5/16"	2	MPDB66230	MPDB66231	MPDB66232	MPDB66233	400	400
3/8"-16 X 1-1/8"	1	3/8"-16 X 1-1/8"	1	MPDB66260	MPDB66261	MPDB66262	MPDB66263	400	400

Hinged Safety Cover for MPDB66 and MPDB67 series: Catalog number MPDBC6667
End Barrier for MPDB66 and MPDB67 series: Catalog Number MPDBE6667

© 2024 Mersen. All rights reserved. Mersen reserves the right to change, update, or correct, without notice, any information contained in this datasheet.

**CATALOG NUMBERS, LARGE ALUMINUM MPDBs,
BOX-BOX CONFIGURATION**

Line Side		Load Side		Catalog Numbers				Ampere Rating per Pole	
Wire Range	Openings per Pole	Wire Range	Openings per Pole	ADDER	Number of Poles			Ratings (Cu)	Ratings (Al)
					1-P	2-P	3-P		
350-6	1	2/0-14	6	MPDB69170	MPDB69171	MPDB69172	MPDB69173	310	250
350-6	1	4-14	12	MPDB69150	MPDB69151	MPDB69152	MPDB69153	310	250
500-4	1	500-4	1	MPDB69050	MPDB69051	MPDB69052	MPDB69053	380	310
500-4	1	350-6	2	MPDB69060	MPDB69061	MPDB69062	MPDB69063	380	310
500-4	1	4/0-6	4	MPDB69510*	MPDB69511*	MPDB69512*	MPDB69513*	380	310
500-4	1	2/0-14	6	MPDB69070	MPDB69071	MPDB69072	MPDB69073	380	310
500-4	1	4-14	12	MPDB69080	MPDB69081	MPDB69082	MPDB69083	380	310
600-2	1	600-2	1	MPDB69640	MPDB69641	MPDB69642	MPDB69643	420	340
1000-250	1	1000-250	1	MPDB69000	MPDB69001	MPDB69002	MPDB69003	545	445
1000-250	1	500-4	2	MPDB69010	MPDB69011	MPDB69012	MPDB69013	545	445
1000-250	1	350-6	2	MPDB69020	MPDB69021	MPDB69022	MPDB69023	545	445
1000-250	1	2/0-14	6	MPDB69030	MPDB69031	MPDB69032	MPDB69033	545	445
1000-250	1	4-14	12	MPDB69040	MPDB69041	MPDB69042	MPDB69043	545	445
4-14	2	4-14	12	MPDB69180	MPDB69181	MPDB69182	MPDB69183	170	130
2/0-14	2	4-14	12	MPDB69160	MPDB69161	MPDB69162	MPDB69163	350	270
2/0-14	2	10-14	20	MPDB69600	MPDB69601	MPDB69602	MPDB69603	350	270
350-6	2	350-6	2	MPDB69120	MPDB69121	MPDB69122	MPDB69123	620	500
313-6 (DLO)		313-6 (DLO)						570 (DLO)	
350-6	2	2/0-14	6	MPDB69130	MPDB69131	MPDB69132	MPDB69133	620	500
350-6	2	4-14	12 ^M	MPDB69140	MPDB69141	MPDB69142	MPDB69143	620	500
313-6 (DLO)		6-14 (DLO)	12					570 (DLO)	
500-4	2	500-4	2 ^M	MPDB69090	MPDB69091	MPDB69092	MPDB69093	760	620
373-4 (DLO)		373-4 (DLO)	2					640 (DLO)	
500-4	2	4/0-6	4	MPDB69310	MPDB69311	MPDB69312	MPDB69313	760	620
373-4 (DLO)		3/0-6 (DLO)						640 (DLO)	
500-4	2	2/0-14	6	MPDB69100	MPDB69101	MPDB69102	MPDB69103	760	620
500-4	2	2/0-14	8	MPDB69350*	MPDB69351*	MPDB69352*	MPDB69353*	760	620
500-4	2	4-14	12	MPDB69110	MPDB69111	MPDB69112	MPDB69113	760	620
373-4 (DLO)		6-14 (DLO)						640 (DLO)	
600-2	2	600-2	2	MPDB69650	MPDB69651	MPDB69652	MPDB69653	840	680
600-2	2	4-14 & 3/0-10	4 & 4	MPDB69540	MPDB69541	MPDB69542	MPDB69543	840	680

* Indicates part numbers that are not UL listed

(DLO) Indicates Ampere Rating or Wire Range applicable to Copper DLO class wire

(M) Indicates connection UL approved for use with multiple conductors in the same opening. Quantities and sizes of wires are as follows:

2/0-#14 Openings	(4) #14	(4) #12	(2) #10						
4/0-#6 Openings	(2) #2	(2) #3	(2) #4	(2) #6					
500-#4 Openings	(2) #4	(2) #3	(2) #2	(2) #1	(2) 1/0	(2) #2/0	(2) 3/0		

**CATALOG NUMBERS, LARGE ALUMINUM MPDBs,
BOX-STUD CONFIGURATION**

Line Side		Load Side		Catalog Numbers				Ampere Rating per Pole	
Wire Range	Openings per Pole	Stud Size	Studs per Pole	ADDER	1-P	2-P	3-P	Ratings (Cu)	Ratings (Al)
500-4	1	3/8"-16 X 1	1	MPDB69210	MPDB69211	MPDB69212	MPDB69213	380	310
500-4	1	3/8"-16 X 1"	2	MPDB69270	MPDB69271	MPDB69272	MPDB69273	380	310
1000-250	1	3/8"-16 X 1"	1	MPDB69280	MPDB69281	MPDB69282	MPDB69283	545	445
500-4	2	3/8"-16 X 1"	2	MPDB69230	MPDB69231	MPDB69232	MPDB69233	760	620

Hinged Safety Cover for MPDB68 and MPDB69 series: Catalog number MPDBC6869

End Barrier for MPDB68 and MPDB69 series: Catalog Number MPDBE6869

**CATALOG NUMBERS, LARGE COPPER MPDBs,
BOX-BOX CONFIGURATION**

Line Side		Load Side		Catalog Numbers				Ampere Rating per Pole	
Wire Range	Openings per Pole	Wire Range	Openings per Pole	ADDER	1-P	2-P	3-P	Cu Wire	
350-6	1	4-14	12	MPDB68150	MPDB68151	MPDB68152	MPDB68153	310	
500-4	1	350-6	2	MPDB68060	MPDB68061	MPDB68062	MPDB68063	380	
2/0-14	2	4-14	12	MPDB68160	MPDB68161	MPDB68162	MPDB68163	350	
350-6	2	350-6	2	MPDB68120	MPDB68121	MPDB68122	MPDB68123	620	
350-6	2	4/0-10	4	MPDB68320*	MPDB68321*	MPDB68322*	MPDB68323*	620	
350-6	2	2/0-14	6	MPDB68130	MPDB68131	MPDB68132	MPDB68133	620	
350-6	2	4-14	12	MPDB68140	MPDB68141	MPDB68142	MPDB68143	620	
500-4	2	500-4	2	MPDB68090	MPDB68091	MPDB68092	MPDB68093	760	
500-4	2	4/0-10	4	MPDB68310	MPDB68311	MPDB68312	MPDB68313	760	
500-4	2	2/0-14	6	MPDB68100	MPDB68101	MPDB68102	MPDB68103	760	
500-4	2	4-14	12	MPDB68110	MPDB68111	MPDB68112	MPDB68113	760	

* Indicates part numbers that are not UL listed

**CATALOG NUMBERS, LARGE COPPER MPDBs,
STUD-BOX CONFIGURATION**

Line Side		Load Side		Catalog Numbers				Ampere Rating per Pole	
Stud Size	Stud per Pole	Wire Range	Openings per Pole	ADDER	1-P	2-P	3-P	Ratings [Cu]	Ratings [Al]
1/2"-13 X 1"	1	4-14	12	MPDB68290	MPDB68291	MPDB68292	MPDB68293	1000	1000

**CATALOG NUMBERS, LARGE COPPER MPDBs,
STUD-STUD CONFIGURATION**

Line Side		Load Side		Catalog Numbers				Ampere Rating per Pole	
Stud Size	Stud per Pole	Wire Range	Stud per Pole	ADDER	1-P	2-P	3-P	Ratings [Cu]	Ratings [Al]
1/2"-13 X 1-3/8"	1	1/2"-13 X 1-3/8"	1	MPDB68220*	MPDB68221*	MPDB68222*	MPDB68223*	400	400

Hinged Safety Cover for MPDB68 and MPDB69 series: Catalog number MPDBC6869

End Barrier for MPDB68 and MPDB69 series: Catalog Number MPDBE6869

© 2024 Mersen. All rights reserved. Mersen reserves the right to change, update, or correct, without notice, any information contained in this datasheet.

The MPDB double-wide series are designed for custom applications where large ampacities are required. Double-wide blocks are not UL or CSA certified unless otherwise noted. All double-wide blocks are Mersen self-certified and approved.

DOUBLE WIDE ALUMINUM CATALOG NUMBERS, BOX-BOX CONFIGURATION

Line Side		Load Side		Catalog Numbers 1-P	Ampere Rating per Pole	
Wire Range	Openings per Pole	Wire Range	Openings per Pole		Cu Wire	Al Wire
1000-250	2	500-4	4	MPDB69561	1090	890
500-4	3	2/0-14	8	MPDB900061	1140	930
600-2	3	600-2	3	MPDB69331	1260	1020
500-4	4	500-4	4	MPDB900071	1520	1240
500-4	4	2/0-12	6	MPDB900121	1520	1240
500-4	4	6-14 & 2/0-14	22 & 4	MPDB69521	1520	1240
500-4	4	4-14	30	MPDB69191	1520	1240
600-2	4	600-2	4	MPDB69341	1680	1360

DOUBLE WIDE COPPER CATALOG NUMBERS, BOX-BOX CONFIGURATION

Line Side		Load Side		Catalog Numbers 1-P	Ampere Rating per Pole
Wire Range	Openings per Pole	Wire Range	Openings per Pole		Cu Wire
500-4	3	4/0-10	6	MPDB800011	1140
500-4	4	500-4	4	MPDB800031	1520
500-4	4	2/0-12	6	MPDB800121	1520
500-4	7	500-4	7	MPDB800061 ^T	2660

^T Indicates that this block is triple-wide

DOUBLE WIDE COPPER CATALOG NUMBERS, BOX-STUD CONFIGURATION

Line Side		Load Side		Catalog Numbers 1-P	Ampere Rating per Pole
Wire Range	Openings per Pole	Stud Size	Studs per Pole		Ratings (Cu)
500-4	4	3/8"-16 X 1"	4	MPDB900091	1520

Hinged Safety Cover for Double-Wide MPDB series: Catalog number MPDBC692W

© 2024 Mersen. All rights reserved. Mersen reserves the right to change, update, or correct, without notice, any information contained in this datasheet.

DIMENSIONS

Miniature (MPDB63133 shown for reference)

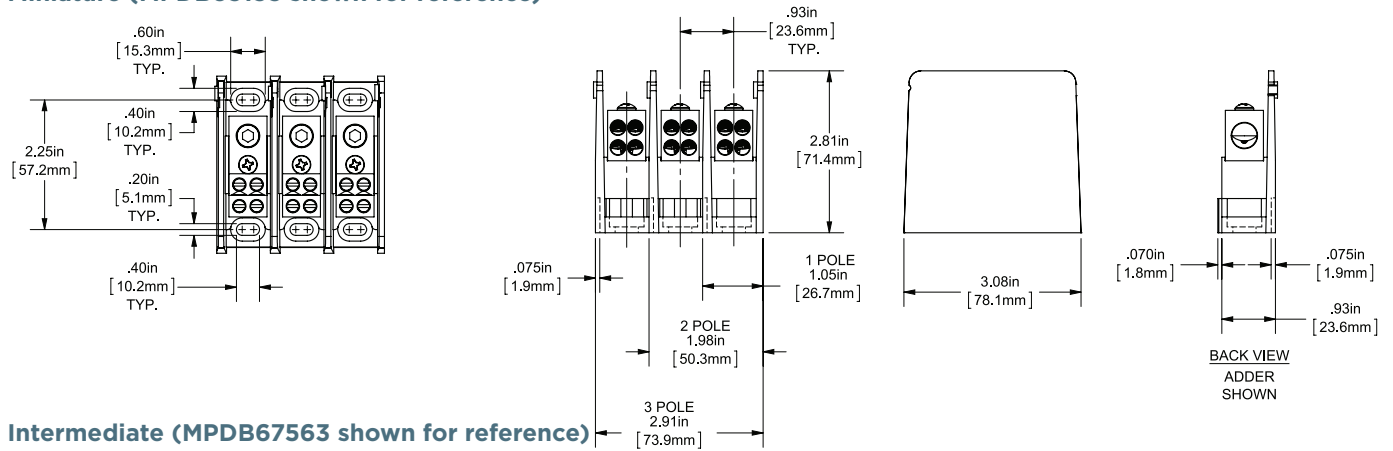

Intermediate (MPDB67563 shown for reference)

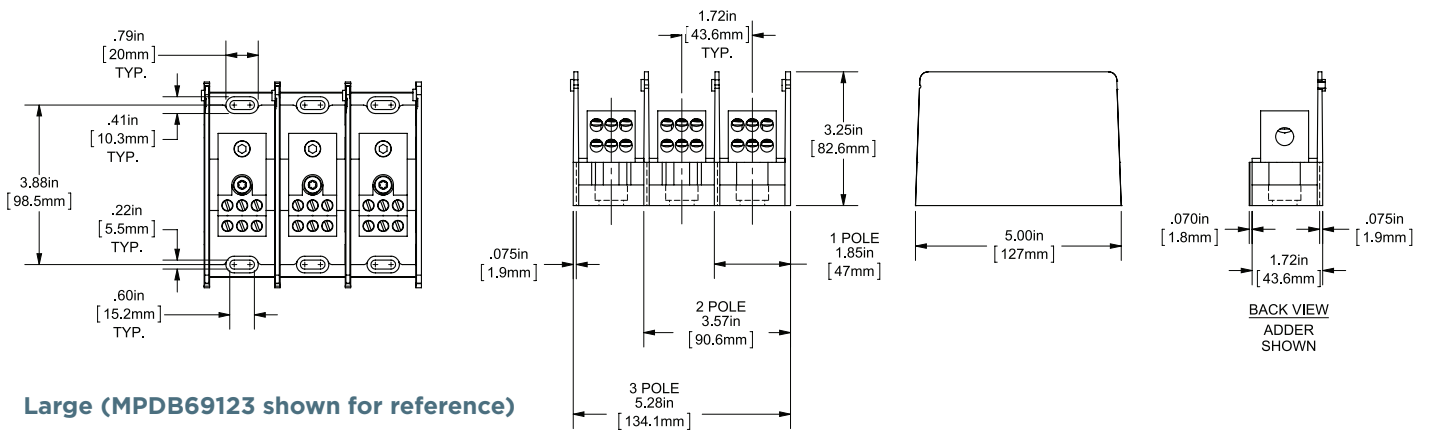

Large (MPDB69123 shown for reference)

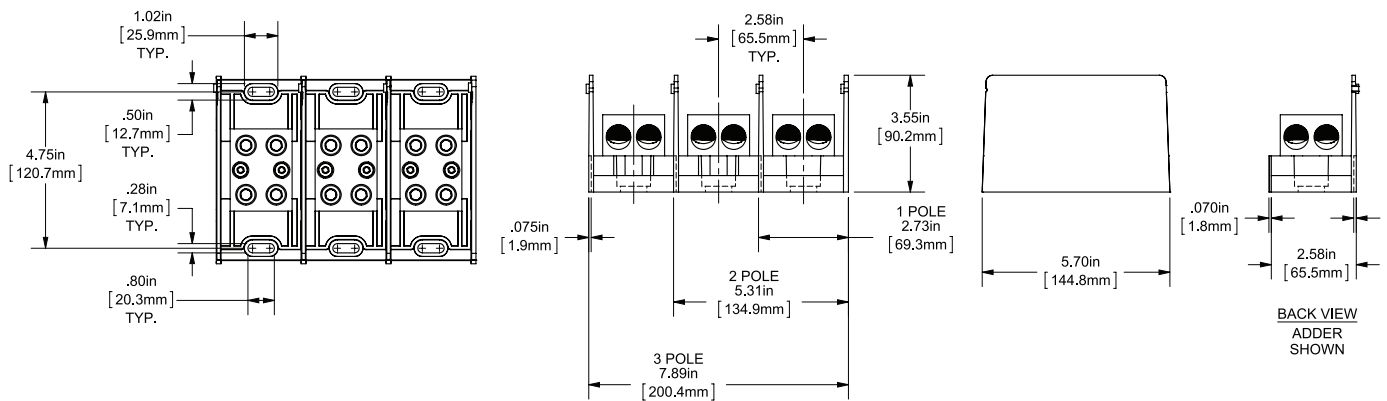

DIMENSIONS (CONTINUED)

Double-Wide (MPDB69331 shown for reference)

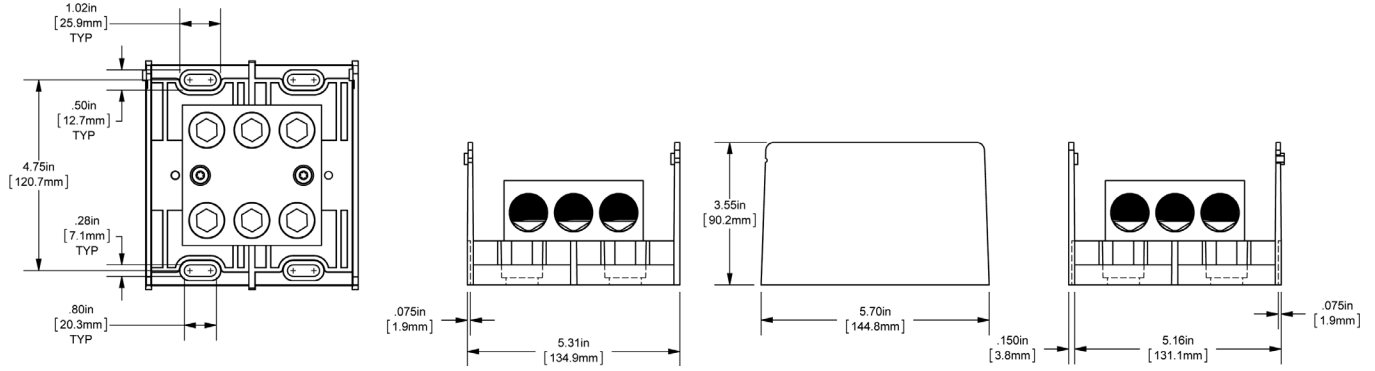

Triple-Wide (MPDB800061 shown for reference)

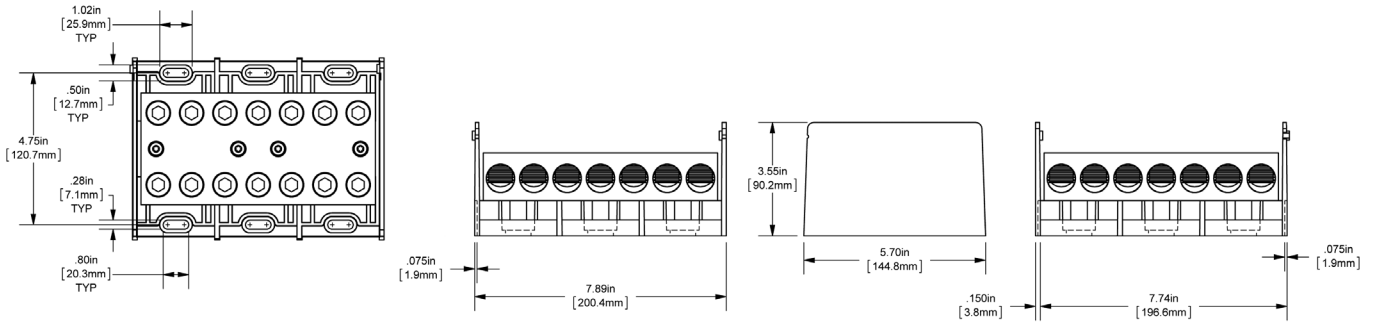

© 2024 Mersen. All rights reserved. Mersen reserves the right to change, update, or correct, without notice, any information contained in this datasheet.